

GP 80/160

1/4 λ Glass fibre Ground-Plane Antenna for the 80 MHz and 160 MHz Bands

DESCRIPTION

- GP 80/160 is a dual-band glass fibre ground-plane antenna of the triple-leg type.
- The antenna is tunable (by cutting) within its main frequency bands: 66...88 MHz/145...175 MHz.
- The cutting diagrams below indicate the length of the radiators and the radials corresponding to specific frequencies within the two bands. It is recommended to use the curves as a guide and fine-tune using an SWR-meter.
- The antenna comprises a brass GP-head, two glass fibre radiators and six glassfiber radials.
- GP 80/160 is made of first-class materials and will endure "wear and tear" for years – no maintenance required.

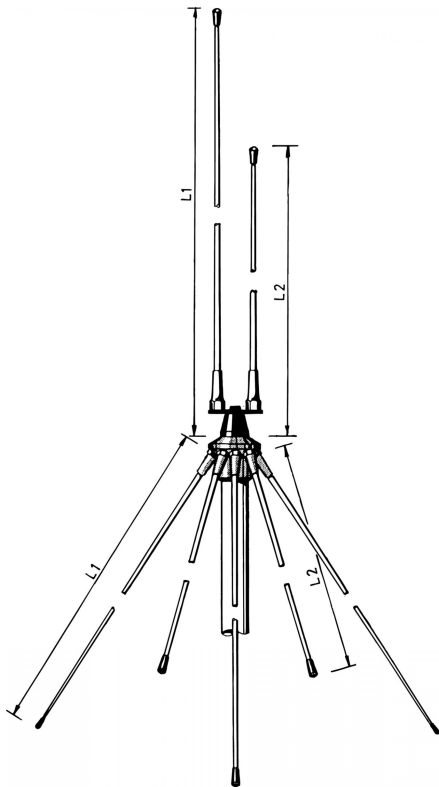

The radiator is measured from its free end to the bottom of the black insulator, while the radials are measured from their free ends to where they meet the GP-head. The radials must be placed short/long alternately.

ORDERING DESIGNATIONS

TYPE	PRODUCT NO.
GP 80/160	10000066
GP 80/160/42 mm	10000067

SPECIFICATIONS

ELECTRICAL	
MODEL	GP 80/160
ANTENNA TYPE	Dual-band 1/4 λ full-size ground-plane
FREQUENCY	66...88 MHz/145...175 MHz
IMPEDANCE	Nom. 50 Ω
RADIATION	Omnidirectional
POLARIZATION	Vertical
GAIN	2 dBi 0 dBd on both bands
BANDWIDTH	Approx. 5 MHz on both bands
SWR	≤ 1.2 @ f. res.
MAX. POWER	250 W
MECHANICAL	
CONNECTOR	N-female
WIND SURFACE	Approx. 0.05 m ²
WIND LOAD	63 N @ 160 km/h
COLOUR	White/bright chrome
MATERIALS	Elements : Glass fibre Metal parts : Bright chromed brass
TOTAL HEIGHT	1.8 m
WEIGHT	Approx. 1.5 kg
MOUNTING	38 mm dia. mast tube (42 mm dia. as option, see note)

PLEASE NOTE

The GP 80/160 can be delivered with a GP-head for mounting on 42 mm dia. mast tube (standard is 38 mm) when ordering as option GP 80/160/42 mm.

CUTTING DIAGRAMS

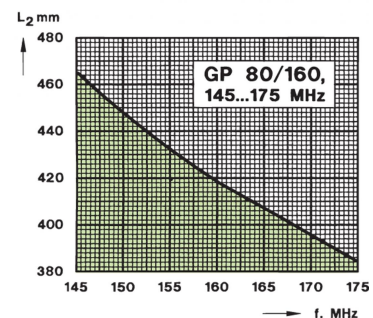
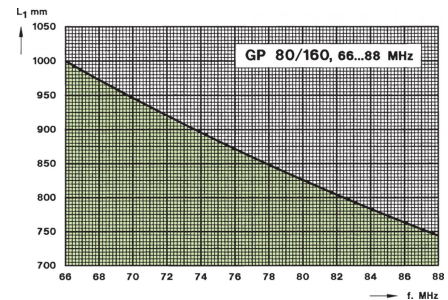

PROCOM France S.A.R.L. se réserve le droit d'améliorer les spécifications sans préavis.

27/10/11